

Materials used: PP and PTFE. Flexible modular system. Five different tubing diameters (3.2 mm; 6.0 mm; 8.0 mm; 10.0 mm and 12.0 mm) can be connected. Sterile pressure equalisation is possible by using the syringe filter. Unused ports can be closed with a blind cap.

Typical applications: safe transfer of liquid media within a closed and sterile system (evaporation is reduced).

Cat. No.	Description	Thread	d (mm)	h (mm)	Pack Unit
1160176		80	86	~ 60	2
Accessories					
1160169	Insert for screw cap GL 18, ID 3.2 mm				1
1160170	Insert for screw cap GL 18, ID 6.0 mm				1
1160171	Insert for screw cap GL 18, ID 8.0 mm				1
1160172	Insert for screw cap GL 18, ID 10.0 mm				1
1160173	Insert for screw cap GL 18, ID 12.0 mm				1
1160174	Screw cap for tube connection, blue, GL 18				2
1160167	Pressure equalisation set for 4-port, GL 18				1
1170682	Screw cap, red, PBT, GL 18				2

DURAN® GLS 80® Connection Cap System

screw cap GLS 80®, with four ports, GL 18 thread

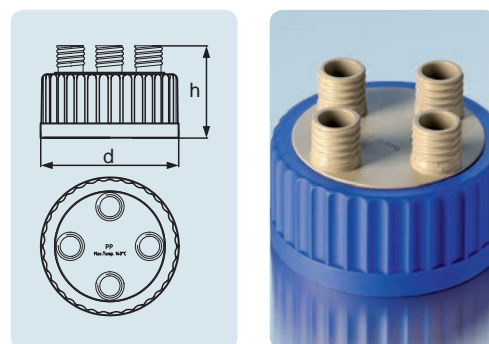

A
121 °C

Tmax.
140 °C

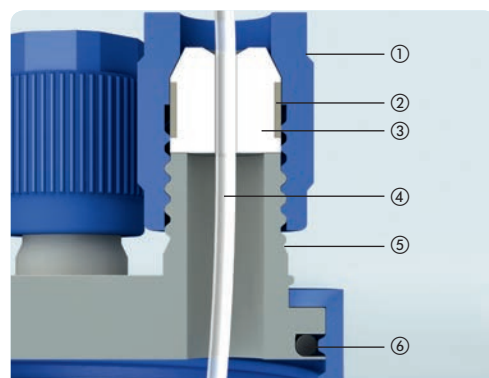

Schematic diagram of GLS 80® connection system

- ① Screw cap GL 14 (PP)
- ② Silicone sealing ring on insert
- ③ PTFE insert / tubing connector
- ④ Tubing (not supplied)
- ⑤ Port (PP)
- ⑥ O-ring seal